

Laser distance sensors

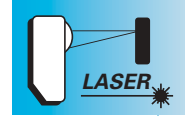

- Accurate distance measuring against different surfaces
- High resolution and accuracy
- Variety of ranges
- Compact sensor without need of external control unit
- Fast response time $< 900 \mu\text{s}$
- Teach-in

Laser distance sensor OADM

Overview

The OADM is a family of laser distance sensors featuring versions that cover ranges from 30 to 1000 mm. The compact sensors provide a precise output signal, that is proportional to the measured distance. Featuring an integrated micro controller, the sensor is completely self contained, needing no external evaluation box. Intelligent in-

ternal signal analysis enables the sensors to work accurately regardless of color and on most surfaces.

With the small visible laser spot the sensors can always be positioned easily and accurately. Distances to rough surfaces can be measured reliably using a fine line instead of the laser spot, thus averaging across a larger area.

Measuring principle

The optical principal is based on triangulation. The laser emits a beam towards the target. The target reflects that beam back to the receiving element. The angle of refraction varies proportionally to the distance of the object. The sensor basically measures this angle and then calculates the distance.

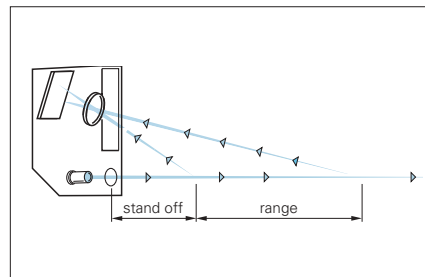

The receiver inside the sensor is a linear photo diode array. The photodiode array is scanned by the built in micro-controller. From the distribution of light along the diode array, the controller precisely calculates the angle, and from the angle, it calculates the distance of the object. This distance is either transferred to the serial port or converted to a distance-proportional output current or output voltage. The microcontroller assures high linearity and precision of the measurement.

The combination of a photo diode array and micro controller allows for suppression of interfering reflections thus providing reliable data on varied and difficult surfaces. The sensor adapts to different colors by changing its internal sensitivity, making it nearly independent of object color.

A digital output is activated when no object is present within the measuring range. Another digital output activates an alarm, if there is not enough light to detect an object correctly (e.g. the sensor is soiled).

The possible resolution and accuracy changes with distance. The same distance Δd , that causes a large angular change α_1 close to the sensor, causes a much smaller angular change α_2 further away (see figure). This non-linear performance will be adjusted by a micro controller, so that the output signal is absolutely linear to the distance.

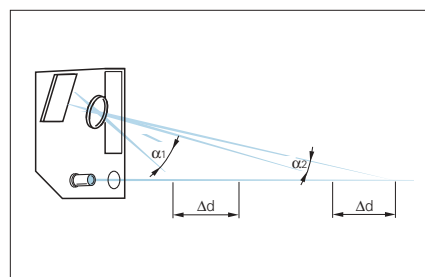

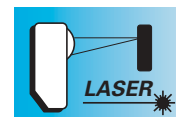

Applications

This sensor family, with its variety of measuring ranges, can be used in many applications.

Typical applications are position, displacement and thickness measurement.

In some applications there are objects with rough and uneven surfaces to measure. Sometimes the object surface has even small holes or gaps. Such objects are easily handled with the option of a laserline optics delivering a fine laser line instead of the narrow focused laser beam.

As for all sensors using triangulation, the laser spot should be positioned in the line of sight of the receiving optics.

As a simple rule, the distance between sensor and objects shall be chosen as small as possible for each application. The shorter the range the higher (more than proportional) the resolution and accuracy.

Advantages

Response time

The measuring cycle takes 10 ms for the standard version and less than 0,9 ms for the fast version.

Built in micro controller

The built in micro controller eliminates the need of an external control unit and makes it easy to place the sensor wherever it is needed. It can transmit the data via serial port without any digitizing error.

Variety of ranges

The same compact housing contains measuring from 20 to 800 mm.

High resolution and accuracy

The photo diode array allows a high accuracy up to $\pm 0,03$ mm and a resolution up to $\pm 0,005$ mm.

Red laser light

The small and highly visible laser spot provides a precise sensing point for easy visual alignment of the sensor even on small objects.

Laser point or laser line

Distances also to rough surfaces are measured reliable, because a laserline is used instead of a laser point.

Surface independent

The linear photo diode array improves measurements on critical surfaces by sophisticated signal processing.

Interface

The measured value is output either as an RS 485, 4 - 20 mA or 0 - 10 V signal.

Teach-in function

The measuring range can be taught within the limits of the device's measuring range by the teach button or by the teach input. The analog output provides the whole 4 - 20 mA / 0 - 10 V signal for the taught measuring range. The resolution and the linearity can be optimized by the taught measuring range. That means the nearer and smaller the taught measuring range the better the resolution and the linearity.

Synch/Hold

The "synch. in" input allows to synchronize two or more laser distance sensors and to hold the measurement value.

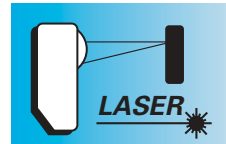

Series 20

- **Wide measuring range**
- **Accurate distance measurement against different surfaces**
- **High resolution**
- **Excellent linearity of output signal due to microprocessor technology**
- **Soiling indicator and alarm output**
- **Current/voltage or RS 485 interface**
- **Laser line for distance measuring on rough surfaces**

connection diagram

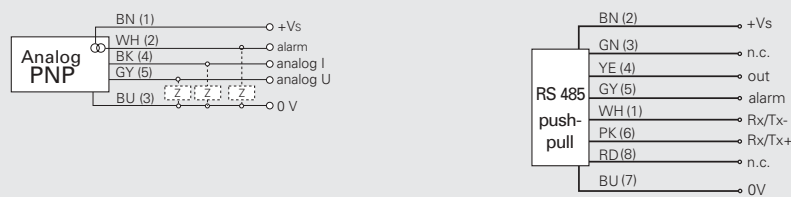

Measuring range
30...50 mm
30...130 mm

Excellent resolution
0,01 mm
0,06 mm

Response time <10 ms

accessories

mounting bracket 131521
 process controller BPCD45 see end of this chapter

orientation of laser line

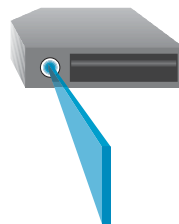

IEC 825-1/1996
21CFR 1040.10

connectors

ES 34CP2B 5 pin 2 m PUR (shielded)
 ESG 34FP0200B 8 pin 2 m PUR (shielded)

suitable for

analog interface (voltage/current)
 RS 485 interface

for details see accessories section

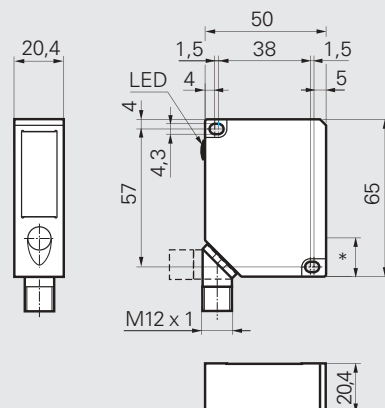

* Emitter axis 16 mm

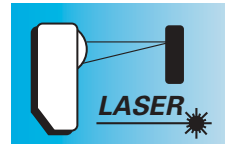

Series 20

- **Wide measuring range**
- **Accurate distance measurement against different surfaces**
- **High resolution**
- **Excellent linearity of output signal due to microprocessor technology**
- **Soiling indicator and alarm output**
- **Current/voltage or RS 485 interface**
- **Laser line for distance measuring on rough surfaces**

connection diagram

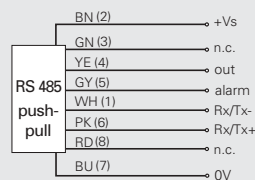
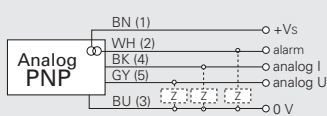

Measuring range
 50...250 mm
 100...500 mm

Excellent resolution
 0,3 mm
 0,5 mm

Response time <10 ms

accessories

mounting bracket 131521
 process controller BPCD45 see end of this chapter

orientation of laser line

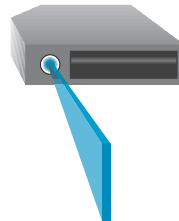

CAUTION
 LASER RADIATION
 DO NOT STARE INTO BEAM
 LASERDIODE
 Wavelength: 630 - 650 nm
 Max. Output: < 1 mW
 Class 2 LASER Product

IEC 825-1/1996
 21CFR 1040.10

connectors

ES 34CP2B 5 pin 2 m PUR (shielded)
 ESG 34FP0200B 8 pin 2 m PUR (shielded)

suitable to

analog interface (voltage/current)
 RS 485 interface

for details see accessories section

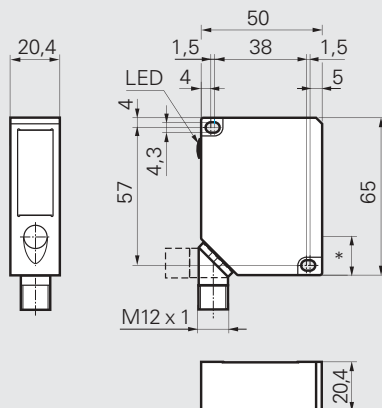

* Emitter axis 16 mm

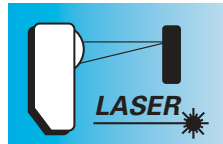

Series 20

- **Wide measuring range**
- **Accurate distance measurement against different surfaces**
- **High resolution**
- **Excellent linearity of output signal due to microprocessor technology**
- **Soiling indicator and alarm output**
- **Current/voltage or RS 485 interface**
- **Laser line for distance measuring on rough surfaces**

connection diagram

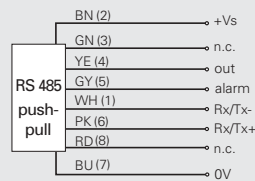
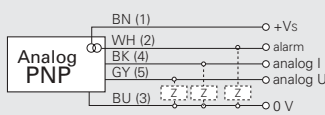

Measuring range
200... 1000 mm

Resolution
3 mm

Response time
<10 ms

Metal housing

accessories

mounting bracket 131521
process controller BPCD45 see end of this chapter

orientation of laser line



CAUTION
LASER RADIATION
DO NOT STARE INTO BEAM
LASERDIODE
Wavelength: 630 - 680 nm
Max. Output: <1 mW
Class 2 LASER Product

IEC 825-1/1996
21CFR 1040.10

connectors

ES 34CP2B 5 pin 2 m PUR (shielded)
ESG 34FP0200B 8 pin 2 m PUR (shielded)

suitable for

analog interface (voltage/current)
RS 485 interface

for details see accessories section

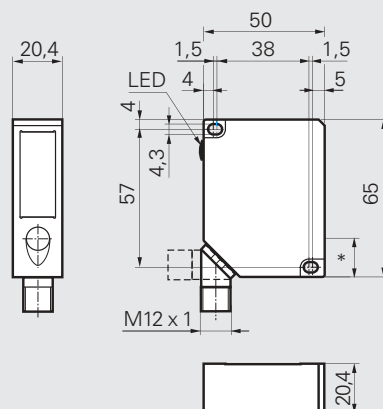

* Emitter axis 16 mm

2
10. 09

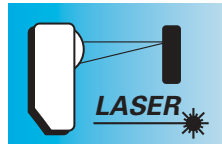

Series 20

- **Teachable measuring range**
- **High resolution optimized by Teach-in**
- **Response time < 900 μs**
- **Excellent linearity of output signal due to microprocessor technology**
- **Accurate distance measurement against different surfaces**
- **Laser line for distance measuring on rough surfaces**
- **Synchronization input**

OADM 2016x41/S14F (typical)

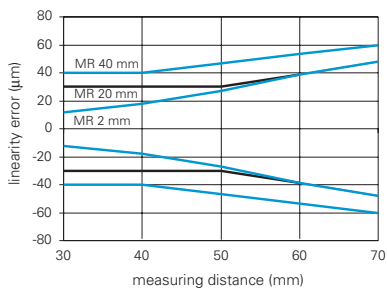
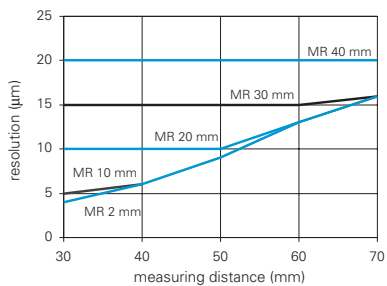

MR = measuring range

OADM 2016x60/S14F (typical)

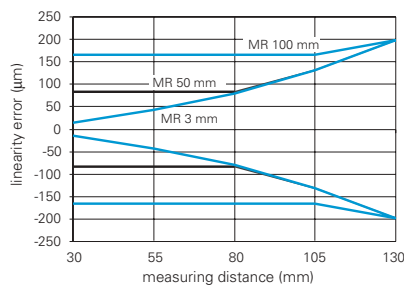
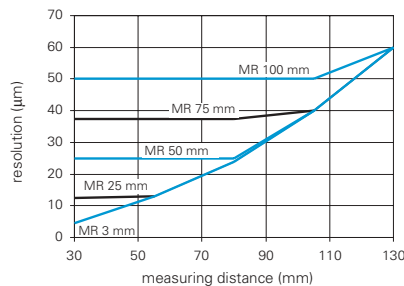

MR = measuring range

Measuring range
30...70 mm
30...130 mm

Resolution
to 0,004 mm
to 0,005 mm

Response time
<900 μs

Teachable measuring range

CAUTION
LASER RADIATION
DO NOT STARE INTO BEAM
LASERDIODE
Wavelength: 630 - 680 nm
Max. Output: < 1 mW
Class 2 LASER Product

IEC 825-1/1996
21CFR 1040.10

accessories

mounting bracket 131521
process controller BPCD45 see end of this chapter

connectors

ESG 34FP0200B 8 pin 2 m PUR (shielded)

for details see accessories section

orientation of laser line

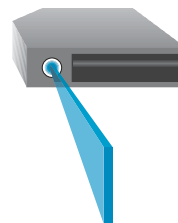

connection diagram

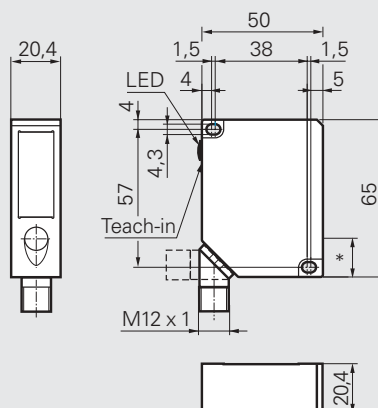
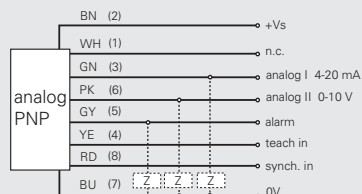

* Emitter axis 16 mm

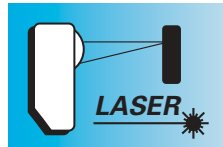

Series 20

- **Teachable measuring range**
- **High resolution optimized by Teach-in**
- **Response time < 900 μs**
- **Excellent linearity of output signal due to microprocessor technology**
- **Accurate distance measurement against different surfaces**
- **Laser line for distance measuring on rough surfaces**
- **Synchronization input**

OADM 2016x72/S14F (typical)

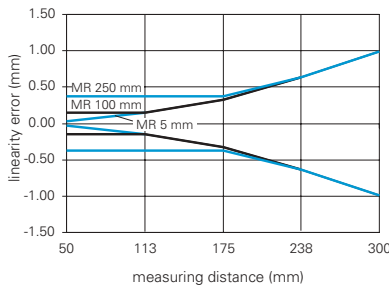
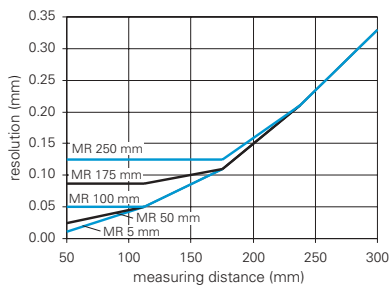

MR = measuring range

OADM 2016x80/S14F (typical)

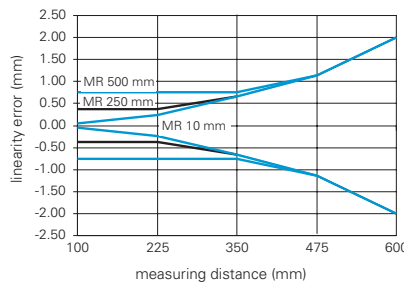
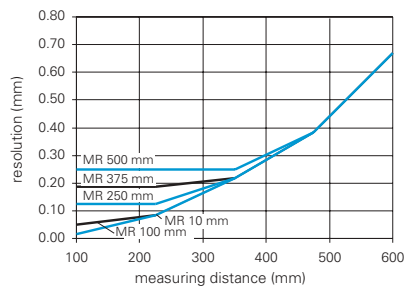

MR = measuring range

Measuring range
50...300 mm
100...600 mm

Resolution
to 0,01 mm
to 0,015 mm

Response time
<900 μs

Teachable measuring range



IEC 825-1/1996
21CFR 1040.10

accessories

mounting bracket 131521
process controller BPCD45 see end of this chapter

connectors

ESG 34FP0200B 8 pin 2 m PUR (shielded)

for details see accessories section

orientation of laser line

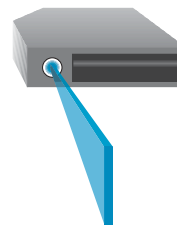

connection diagram

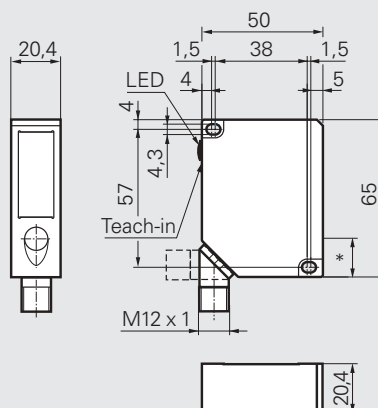
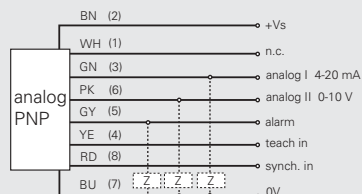

* Emitter axis 16 mm

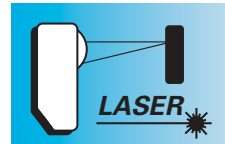

Series 20

- **Teachable measuring range**
- **High resolution optimized by Teach-in**
- **Response time < 900 μ s**
- **Excellent linearity of output signal due to microprocessor technology**
- **Accurate distance measurement against different surfaces**
- **Laser line for distance measuring on rough surfaces**
- **Synchronization input**

OADM 20I6x81/S14F (typical)

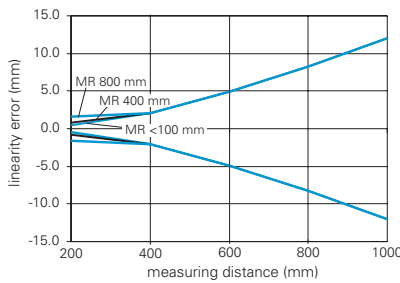
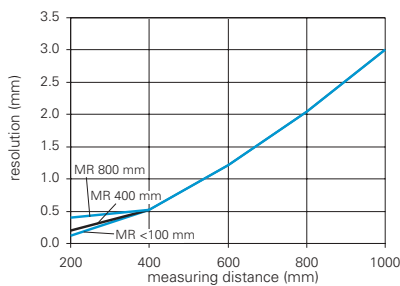

MR = measuring range

accessories

mounting bracket 131521
process controller BPCD45 see end of this chapter

connectors

ESG 34FP0200B 8 pin 2 m PUR (shielded)

for details see accessories section

orientation of laser line



connection diagram

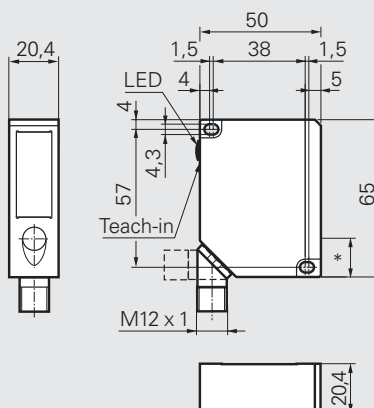
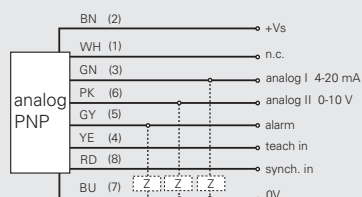

* Emitter axis 16 mm

Measuring range
200...1000 mm

Resolution
0,12 mm

Response time
<900 μ s

Teachable measuring range



IEC 825-1/1996
21CFR 1040.10

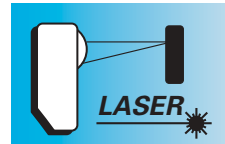

Series 21

- **Teachable measuring range**
- **Excellent resolution by Teach-in**
- **Current/voltage output**
- **Excellent linearity of output signal due to microprocessor technology**
- **Accurate distance measurement against different surfaces**
- **Soiling indicator and alarm output**
- **Laser line for distance measuring on rough surfaces**

connection diagram

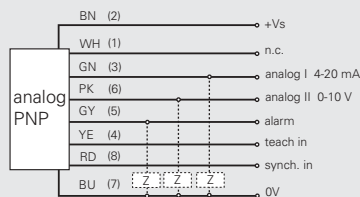

Measuring range
200...1000 mm

Excellent resolution
0,03 mm

Response time
<10 ms

Teachable measuring range

accessories

process controller

BPCD45 see end of this chapter

orientation of laser line

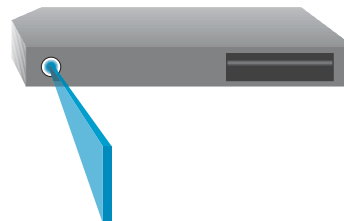

connectors

ESG 34FP0200B 8 pin 2 m PUR (shielded)

for details see accessories section

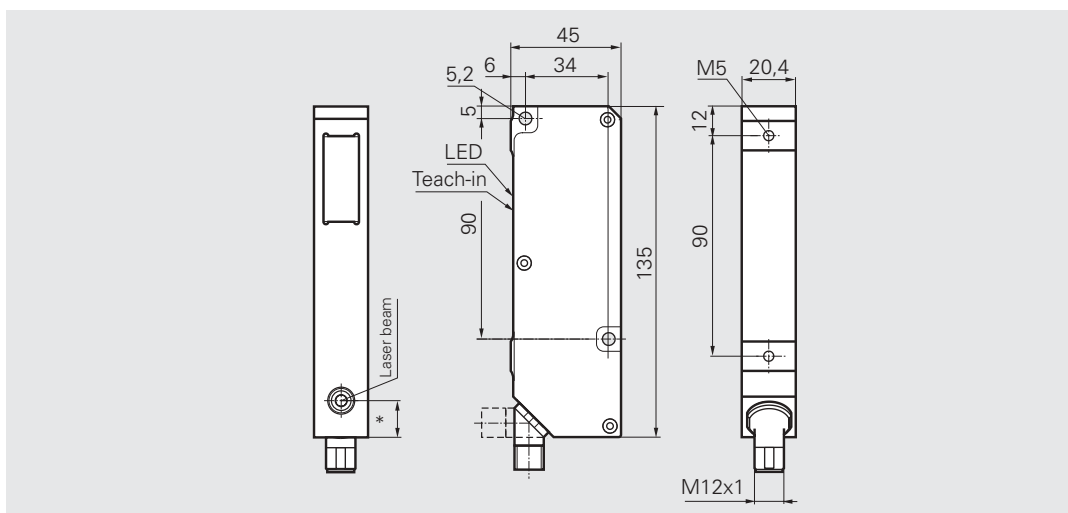

* Emitter axis 15 mm



IEC 825-1/1996
21CFR 1040.10

Electronic Process Controller and Display BPCD45

Process controller

BPCD45



part number	
interface	index
inputs / outputs	index
supply voltage	index

BPCD45. x x x 1	
B/C/D	
B	without interface
C	RS 422 / RS 485
D	RS 232
0/1/2/3	
0	input 0...10 V / output -10...10 V
1	input 0...20 mA / output -10...10 V
2	input 0...10 V / output 0...10 V
3	input 0...20 mA / output 0...10 V
2/3	
2	85...265 VAC
3	18...30 VDC

electrical data	
supply voltage	
power consumption	
sensor supply	
control inputs	
limit value P1, P2	
analog inputs	
analog outputs	
data storage	
response time	
mechanical data	
display	
operation, keypad	
front dimensions	
mounting	
fastening	
weight	
connection	
core cross-section	
housing material	
front membrane	
environmental conditions	
ambient temperature	
storage temperature	
relative humidity	
protection class	
general rating	
interference immunity	
emitted interference	

85...265 VAC (50 / 60 Hz) / 18...30 VDC
12 VA, 10 W
18 VDC ±10 % max. 350 mA
3 control inputs, PNP/NPN-Logic, voltage range 4...40 V, input resistor 3 kΩ
2 dry-closure relays programmable as permanently open or closed max. switch volt. 250 VAC / 110 VDC, max. switch current 1 A at Ω load, switch performance 150 VA / 30 W
2 Inputs 0(2)...10 V, 0(4)...20 mA, resolution 12 Bit both offset and upper as well as lower analog values to be programmed by front keys
3 outputs at -10...+10 VDC or 0...+10 VDC each, resolution 12 Bit offset as well as lower and upper analog limit can be programmed
> 10 years via EEPROM
≤ 20 ms
7-segment LED-display, 6-digit display of real values, 14 mm high, decimal point can be programmed, suppression of leading zero
front membrane with short-stroke keys
DIN housing 96 x 48 mm
Front-plate installation
by means of clamping frame
approx. 300 g
plug-in screw terminals, Grid 5,08 mm
max. 1,5 mm²
polycarbonate black, UL 94V-0
polyester
0...+60 °C
-20...+70 °C
max. relative humidity 95 %
front IP 65 to DIN 40050
EN 61010 part 1, protection class II, overvoltage protection categ. II, contamination factor 2
EN 61000-6-2
EN 50081-1



BPCD45

- Extra bright 6-digit LED display
- Two analog inputs
- Three analog outputs
- Two programmable limit values
- Calculation functions
Difference, Stretching/Shrinking, Ratio, Total
- Interfaces RS 485, RS 422, RS 232

application

The BPCD45 is designed to display and process measurements. Voltage as well as current input signals can be used. Their corresponding information can be read out via F1 and F2. Both measuring values F1 and F2 are processed internally and displayed by F3. F1, F2 and F3 are forwarded for direct control as individual analog output signals -10...+10 VDC / 0...+10 VDC. Two programmable limit values P1 and P2 with three classifications allow the monitoring of production processes. In addition BPCD45 is equipped with an electronic data storage of the peak value, that can be programmed by the operator to F1, F2 or F3.

block diagram

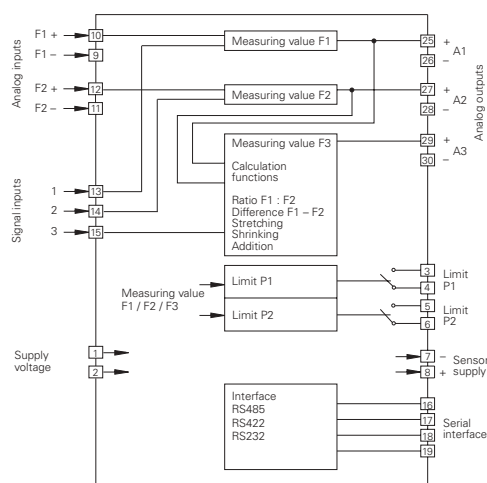

6-digit
LED display

2 analog
inputs

3 analog
outputs

Two
programmable
limit values

pin assignments

