

**4**

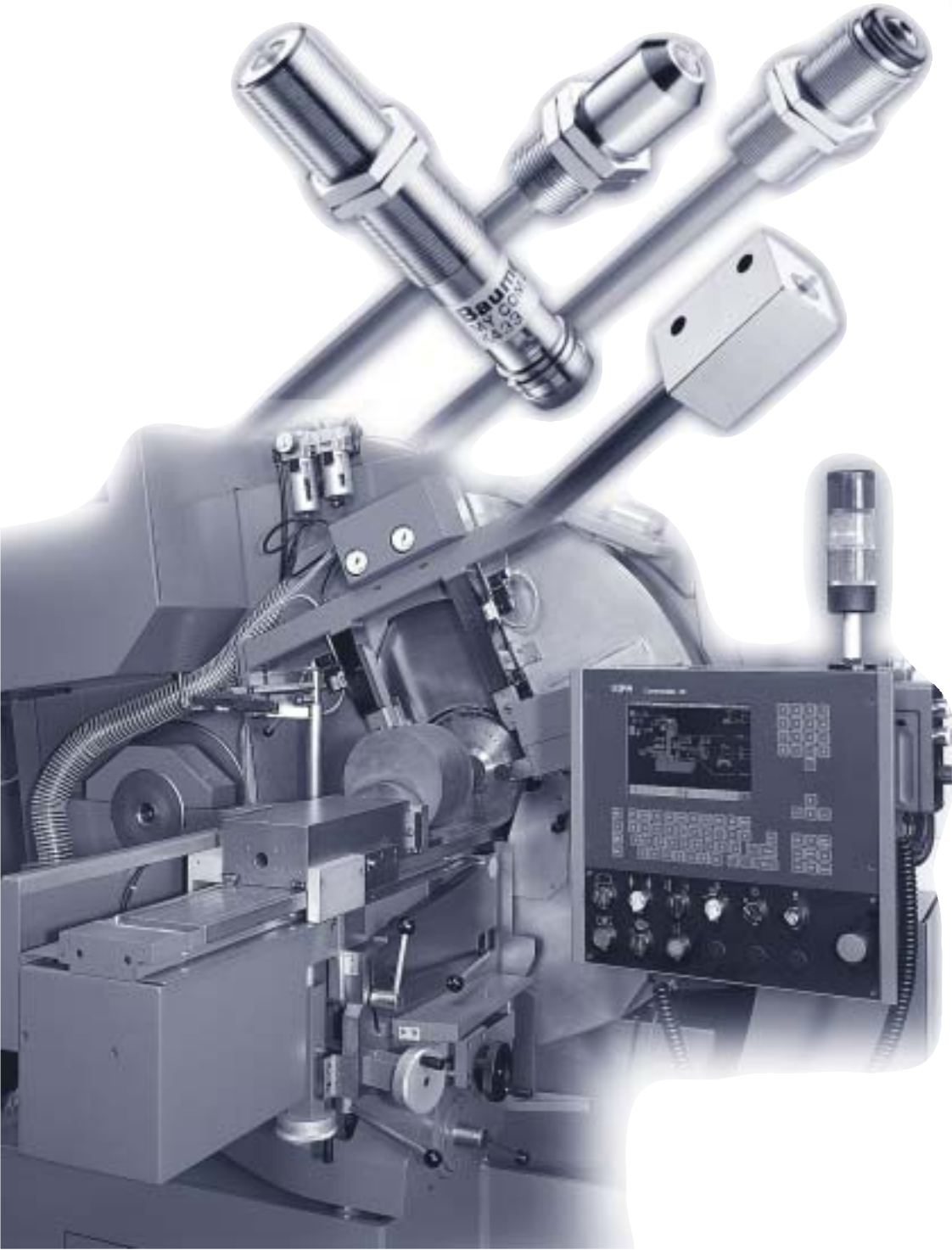

**My-Com Line**

***My-Com – the precision switch  
with 1μ repeatability!***



<b>1</b>	<b>Introduction</b>	<b>Page 1. 04 - 1. 05</b>
----------	---------------------	---------------------------

<b>2</b>	<b>My-Com precision switch- Types A, B, BS</b>	<b>Page 2. 02</b>
----------	--	-------------------

	<b>My-Com precision switch- Types C, F, E</b>	<b>Page 2. 03</b>
--	---	-------------------

	<b>My-Com precision switch- Types H, D</b>	<b>Page 2. 04</b>
--	--	-------------------

	<b>My-Com precision switch- Types G, L</b>	<b>Page 2. 05</b>
--	--	-------------------

	<b>My-Com precision switch- Type M</b>	<b>Page 2. 06</b>
--	--	-------------------

	<b>Connectors</b>	<b>Page 2. 07</b>
--	-------------------	-------------------

<b>3</b>	<b>Amplifiers</b>	<b>Page 3. 02</b>
----------	-------------------	-------------------

<b>4</b>	<b>Mounting guidelines</b>	<b>Page 4. 02</b>
----------	----------------------------	-------------------

# My-Com ultra precision switches

## Introduction

### Ultra-precision switches

Baumer electric has specialized for over 50 years in the research, development and manufacturing of high precision switching devices for technical applications.

Quality control at every step of manufacturing and assembly plus 100% final testing ensures that Baumer electric products detect and switch with total reliability in all applications.

### The My-Com concept – Repeat accuracy $\pm 0,001$ mm / $0,00004$ "

The My-Com is the most accurate mechanical switch available with a switching point sensitivity of only  $\pm 1$  micron (40 millionths of an inch!).

It is the ideal solution for applications where extremely accurate set points are needed.

The unique design of the My-Com includes a gold-plated ball and contacts to minimize electrical resistance across the switch. Zirconium oxide, Ruby or hardened steel is used for the activator to minimize thermal effects and wear.

The range of My-Com housings and outputs offer you a complete selection for your set point applications.

## Applications

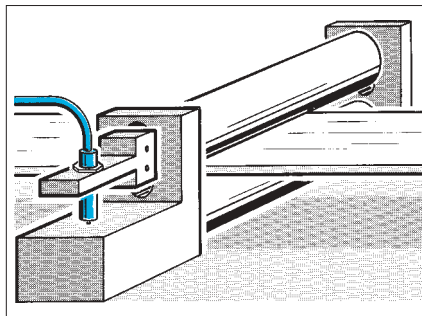

### Quality control

The My-Com is used in mass production as a measuring and control instrument. Its precision operation can indicate whether the articles concerned are within manufacturing tolerances, for example built into a control gauge to measure length, diameter or concentricity.

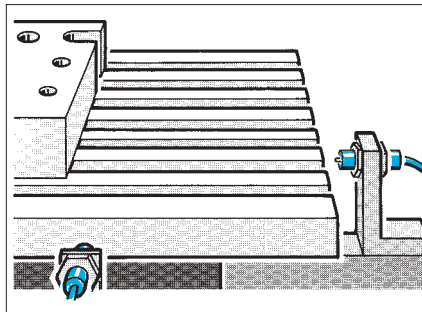

### Precision finishing

The My-Com is used as a control and guiding instrument for processing machines, for example as a control stop on positioning tables for drilling, milling, turning and grinding on automatic equipment.

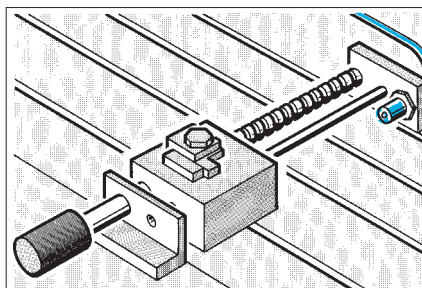

### Limit control

The My-Com detects small expansions or contractions due to temperature and pressure differences.

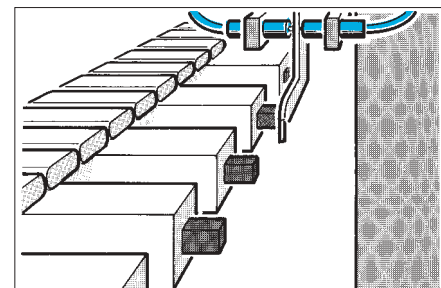

# Technical specifications



## Technical characteristics

### Mechanical data

Repeatability	± 0,001 mm (1 micron)
Reset (Hysteresis)	≤ 0,002 mm
Mechanical lifetime	10'000'000 switchings
Switching frequency	0 - 10 Hz
Max. activating velocity	< 30 mm/s
Temperature range	-20 °C to + 75 °C (-5 °F to + 165 °F)
Standard cable length	80 cm
Standard conductor cross section	0,14 mm <sup>2</sup>
Standard cable material	PVC
Protection class (standard)	IP 50

### Transistor output

The My-Com types L, G and M are available with a transistorized output. When supplied with this configuration, the output circuit is supplied normally open (NO). A protective diode is incorporated into the circuit to protect against transients.

### LED indicator

The My-Com types with transistor output are available with LED output indicators.

### Increased environmental protection (IP 67)

For applications in harsh environments (dust, oil, cooling fluid) we recommend the waterproof My-Com D, H or M. The My-Com type L, with transistor output, is also available with the same protection (IP 67). The sealing membrane for all of these is made of Viton.

### Maximum installation torque (not lubricated)

If the published installation torque specifications prove to be insufficient for your application, we recommend using a nut locking liquid to secure the My-Com. The published specifications for maximum torque must not be exceeded!

### Wire color code

BN = Brown  
BK = Black  
BU = Blue

### Max. torque figures (not lubricated)

My-Com D	20 Nm
My-Com E	5,5 Nm
All others	3,5 Nm

## Part number key



### Example

**My-Com F 50 / 80**

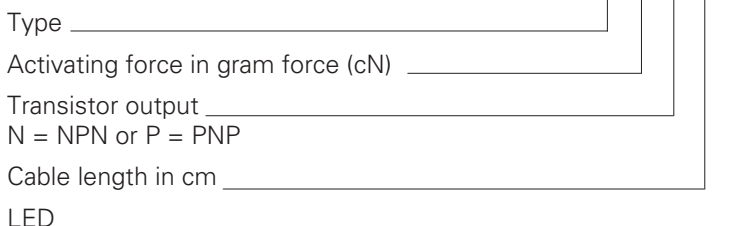

**My-Com L 75 N 80 /L**



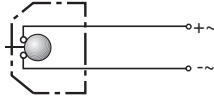
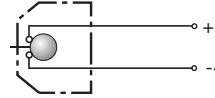
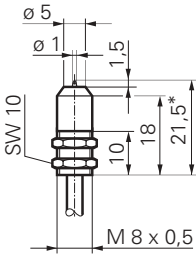
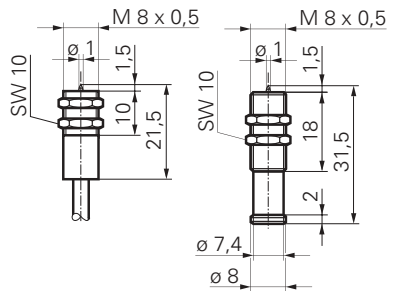

# My-Com precision switches

		My-Com A	My-Com B / My-Com BS
			
activating force	30 gram force (cN)	<b>My-Com A30/80</b>	<b>My-Com B30/80</b>
	50 gram force (cN)	<b>My-Com A50/80</b>	<b>My-Com B50/80</b>
	75 gram force (cN)	<b>My-Com A75/80</b>	<b>My-Com B75/80</b>
	100 gram force (cN)	<b>My-Com A100/80</b>	<b>My-Com B100/80</b>
electrical data	max. AC voltage	24 VAC	24 VAC
	max. switch. current AC	50 mA	50 mA
	max. DC voltage	15 VDC	15 VDC
	max. switch. current DC	2 mA	2 mA
activating force	NPN 75 gram force (cN)		
	PNP 75 gram force (cN)		
electrical data	max. supply voltage		
	max. load current at 24 VDC		
	min. load resistance		
	output		
actuator tip		zirconium oxide ZrO <sub>2</sub>	zirconium oxide ZrO <sub>2</sub>
housing		brass nickel plated	brass nickel plated
special features		protection class IP 50	protection class IP 50
connection diagram / output function			
		normally closed (NC) / break function	normally closed (NC) / break function
options		for connector base version, remove <b>.../80</b> and add <b>.../S35</b> * length with connector base S35 approximately 30 mm	for connector base version remove <b>.../80</b> and add <b>S</b> to the part number. For example: My-Com B30/80 (cable version) My-Com <b>BS</b> 30 (connector version)
		overrun 1,5 mm approx.	overrun 1,5 mm approx.
			

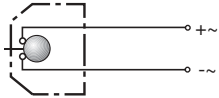
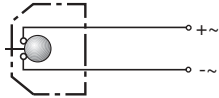
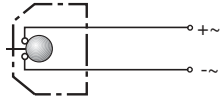
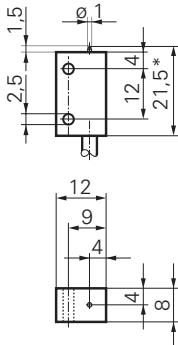
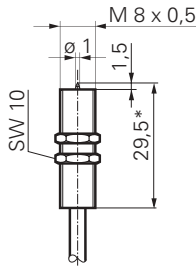
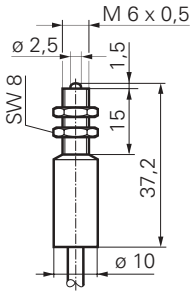

# My-Com precision switches

My-Com C	My-Com F	My-Com E
		
<b>My-Com C30/80</b>	<b>My-Com F30/80</b>	
<b>My-Com C50/80</b>	<b>My-Com F50/80</b>	
<b>My-Com C75/80</b>	<b>My-Com F75/80</b>	<b>My-Com E75/80</b>
<b>My-Com C100/80</b>	<b>My-Com F100/80</b>	<b>My-Com E100/80</b>
24 VAC	24 VAC	24 VAC
50 mA	50 mA	50 mA
15 VDC	15 VDC	15 VDC
2 mA	2 mA	2 mA
zirconium oxide ZrO <sub>2</sub>	zirconium oxide ZrO <sub>2</sub>	hardened steel
brass nickel plated	brass nickel plated	brass nickel plated
protection class IP 50	protection class IP 50	protection class IP 50
		
normally closed (NC) / break function	normally closed (NC) / break function	normally closed (NC) / break function
for connector base version, remove .../80	for connector base version, remove .../80	
and add .../S35	and add .../S35	
* length with connector base S35	* length with connector base S35	
approximately 30 mm	approximately 38 mm	
overrun 1,5 mm approx.	overrun 1,5 mm approx.	overrun 0,8 - 1,2 mm approx.
		

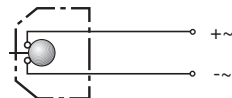
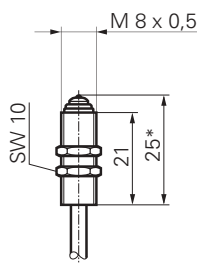
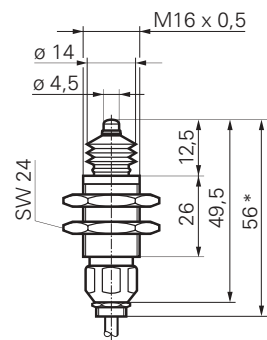

# My-Com precision switches

		My-Com H	My-Com D
			
		<b>My-Com H75/80</b>	<b>My-Com D250/80</b>
activating force	30 gram force (cN) 50 gram force (cN) 75 gram force (cN) 250 gram force (cN)		
electrical data	max. AC voltage	24 VAC	24 VAC
	max. switch. current AC	50 mA	50 mA
	max. DC voltage	15 VDC	15 VDC
	max. switch. current DC	2 mA	2 mA
activating force	NPN 75 gram force (cN) PNP 75 gram force (cN)		
electrical data	max. supply voltage		
	max. load current at 24 VDC		
	min. load resistance		
	output		
actuator tip		ruby	hardened steel
housing		brass nickel plated	browned brass
special features		protection class IP 67	protection class IP 67
connection diagram/output function		 normally closed (NC) / break function	 normally closed (NC) / break function
options		for connector base version, remove .../80 and add .../S35 * length with connector base S35 approximately 44 mm	for connector base version, remove .../80 and add .../S35 * length with connector base S35 approximately 74 mm
		overrun 0,6 mm approx.	pre-run / overrun 1 mm approx.
			

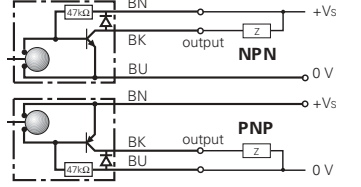
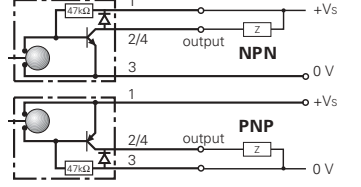
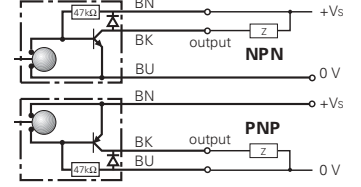
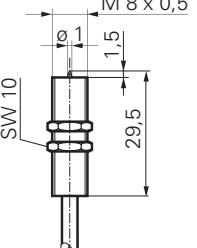
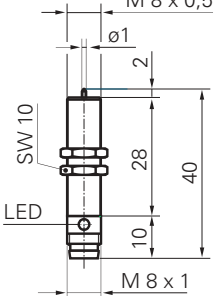
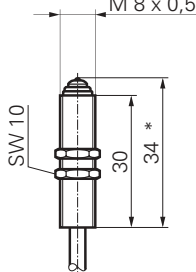

# My-Com precision switches

My-Com G	My-Com G	My-Com L
		
<b>My-Com G75N80/L</b> <b>My-Com G75P80/L</b>	<b>My-Com G75N/S35L</b> <b>My-Com G75P/S35L</b>	<b>My-Com L75N80/L</b> <b>My-Com L75P80/L</b>
5 - 36 VDC	5 - 36 VDC	5 - 36 VDC
50 mA	50 mA	50 mA
480 Ω	480 Ω	480 Ω
normally open (NO)	normally open (NO)	normally open (NO)
zirconium oxide ZrO <sub>2</sub>	zirconium oxide ZrO <sub>2</sub>	ruby
brass nickel plated	brass nickel plated	brass nickel plated
transistor output NPN / PNP	transistor output NPN / PNP	transistor output NPN / PNP
protection class IP 50	protection class IP 50	protection class IP 67
		
		for connector base version, remove .../80 and add .../S35L * length with connector approx. 44 mm
overrun 1,5 mm approx.	overrun 1,5 mm approx.	overrun 0,6 mm approx.
		

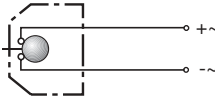
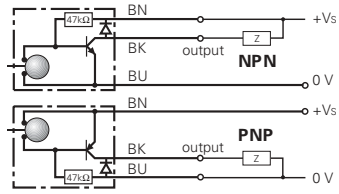
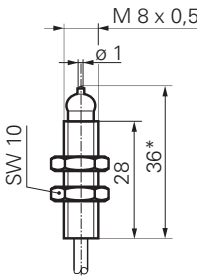
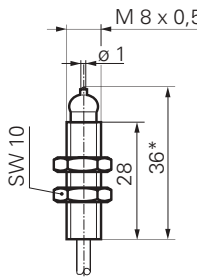
# My-Com precision switches

		My-Com M	My-Com M
			
		<b>My-Com M75/80</b>	
activating force	30 gram force (cN) 50 gram force (cN) 75 gram force (cN) 100 gram force (cN)		
electrical data	max. AC voltage max. switch. current AC max. DC voltage max. switch. current DC	24 VAC 50 mA 15 VDC 2 mA	
activating force	NPN 75 gram force (cN) PNP 75 gram force (cN)		<b>My-Com M75N80</b> <b>My-Com M75P80</b>
electrical data	max. supply voltage max. load current at 24 VDC min. load resistance output		5 - 36 VDC 50 mA 480 Ω normally open (NO)
actuator tip		zirconium oxide ZrO <sub>2</sub>	zirconium oxide ZrO <sub>2</sub>
housing		brass nickel plated	brass nickel plated
special features		silicone gasket protection class IP 67	silicone gasket protection class IP 67
connection diagram / output function			
options		for connector base version, remove .../80 and add .../S35 * length with connector approx. 46 mm	for connector base version, remove .../80 and add .../S35 * length with connector approx. 46 mm
		overrun 1,5 mm approx.	overrun 1,5 mm approx.
			

# Connectors

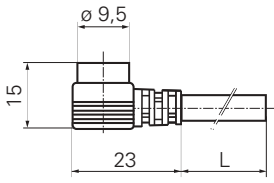
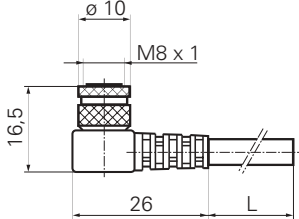
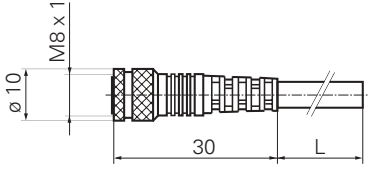
Connector ES 30	Connector ESW 31	Connector ESG 32
		
Part number ES 30.2 For My-Com BS Cable length 2 m PVC 2-pin	Part number ESW 31SH0200 For .../S35 connector base Cable length 2 m PUR halogen-free 3-pin	Part number ESG 32SH0200 For .../S35 connector base Cable length 2 m PUR halogen-free 3-pin
		

## Connection diagrams for My-Coms with 3 wires

When supply voltage and load voltage are different, My-Com without LED should be used (open collector output).

## S35 connector base pin out

(viewed from rear of My-Com)

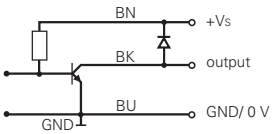
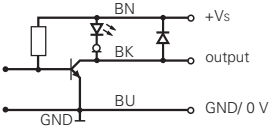
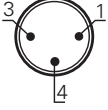
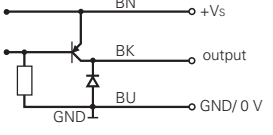
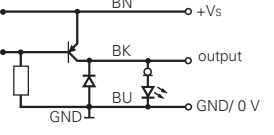
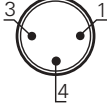
<p><b>NPN without LED</b></p> 	<p><b>NPN with LED</b></p> 	<p><b>3-wire version, with transistorized output</b></p>  <table border="1"> <thead> <tr> <th>Pin-Nr.</th> <th>Color</th> <th>Signals</th> </tr> </thead> <tbody> <tr> <td>1</td> <td>BN (Brown)</td> <td>+Vs</td> </tr> <tr> <td>3</td> <td>BU (Blue)</td> <td>0V</td> </tr> <tr> <td>4</td> <td>BK (Black)</td> <td>Output</td> </tr> </tbody> </table>	Pin-Nr.	Color	Signals	1	BN (Brown)	+Vs	3	BU (Blue)	0V	4	BK (Black)	Output
Pin-Nr.	Color	Signals												
1	BN (Brown)	+Vs												
3	BU (Blue)	0V												
4	BK (Black)	Output												
<p><b>PNP without LED</b></p> 	<p><b>PNP with LED</b></p> 	<p><b>2-wire version, non transistorized output</b></p>  <table border="1"> <thead> <tr> <th>Pin-Nr.</th> <th>Color</th> <th>Signals</th> </tr> </thead> <tbody> <tr> <td>1</td> <td>BN (Brown)</td> <td>+Vs</td> </tr> <tr> <td>3</td> <td>BU (Blue)</td> <td>0V</td> </tr> <tr> <td>4</td> <td>BK (Black)</td> <td>n.c.</td> </tr> </tbody> </table>	Pin-Nr.	Color	Signals	1	BN (Brown)	+Vs	3	BU (Blue)	0V	4	BK (Black)	n.c.
Pin-Nr.	Color	Signals												
1	BN (Brown)	+Vs												
3	BU (Blue)	0V												
4	BK (Black)	n.c.												